

# MILLENNIUM CATALOG

# INDEX

|         |   |         |                                  |
|---------|---|---------|----------------------------------|
| 126     | 3 - position shelves                        | 132     | hangrods                         |
| 126     | 4 - position shelves                        | 128     | heavy duty wire baskets          |
| 132     | accessories                                 | 122-124 | island and wall backs            |
| 128     | accessories - wire fencing for shelves      | 117     | island trim - prefinished        |
| 131     | adjustable bracket                          | 117     | island trim - painted            |
| 121     | anchor plate                                | 121     | load easers                      |
| 118     | base bracket-lowbase                        | 131     | metal facia                      |
| 118     | standard base                               | 131     | metal facia components           |
| 118     | base bracket trim-lowbase and standard base | 131     | metal returns                    |
| 125     | base deck                                   | 123     | perforated back panels           |
| 120     | base front                                  | 119     | reinforced bottom rails          |
| 129     | basket dividers                             | 128     | reversible wire shelves          |
| 128     | basket/shelf brackets                       | 131     | shelf mount brackets             |
| 119     | bottom rail                                 | 119     | splicer rails                    |
| 119     | center rail                                 | 124     | slat wall back panels            |
| 122-124 | component parts - back panels               | 119     | slat wall center rails           |
| 119     | component parts - cross components          | 122     | solid back panels                |
| 117     | component parts - uprights                  | 120     | support channels                 |
| 132     | display accessories                         | 120     | support clips                    |
| 128     | endless wire basket                         | 119     | top rails                        |
| 122-124 | extender backs                              | 117     | uprites                          |
| 117     | extender end trim                           | 121     | uprite anchors                   |
| 117     | extender upright                            | 121     | uprite caps                      |
| 117     | extender upright trim                       | 117     | uprite trim                      |
| 132     | flange bracket                              | 116     | wall end exploded                |
| 120     | flush base                                  | 132     | wall end stabilizer              |
| 129     | front/back wire fence                       | 116     | wall trim exploded               |
| 129     | front-to-back wire dividers                 | 116     | wall trim - painted exploded     |
| 127     | glass shelf accessories                     | 116     | wall trim - prefinished exploded |
| 127     | glass shelf brackets                        |         |                                  |
| 127     | glass shelf tops                            |         |                                  |
| 127     | glass shelves                               |         |                                  |

# TERMS AND CONDITIONS OF SALE

**Price and Acceptance:** Streater reserves the right to change its prices and other terms and/or conditions of sale without notice. All orders placed shall be in writing and become effective only upon acceptance by Streater at its offices in Albert Lea, MN. Streater at its discretion may add handling charges depending on order size and/or order requirements.

**Taxes:** Buyer agrees to pay all taxes which Streater may be required to assess. If buyer claims a tax exempt status, buyer will provide Streater with a valid tax-exemption certificate.

**Payment Terms:** Payment to Streater will be cash with order or net 30 days to qualified buyers, upon approval by Streater Credit Department. Overdue payments will be assessed interest charges at the legal rate of the State of Minnesota or the state of the buyer's residence, whichever is greater.

**Freight and Delivery:** Freight is F.O.B. Albert Lea, MN. Method and route of delivery are at Streater's discretion unless Streater is furnished with complete shipping instructions at least 10 days before the scheduled ship date. Time-sensitive delivery will be handled at Streater's discretion. Quotations for time-sensitive delivery are available upon request. Freight charges will be prepaid and added to the invoice unless otherwise instructed. Streater will endeavor to ship on the requested ship date and every effort will be made to fill orders completely; however, it may be necessary at times to backorder. Streater will not be liable for any delay in the performance of any order or contract, or in the delivery of any goods, or for any damages resulting from such delay, when such delay is due to fire, riots, acts of God, strikes or other events beyond the control of Streater.

**Freight and Damage Claims:** Freight is F.O.B. Albert Lea MN. What this means is that title to the product is passed on to you when the freight carrier picks up the shipment from Streater and signs the bill of lading. Any freight damage and resultant claims are between you and the freight carrier. It is your responsibility to file a freight claim.

**Loss of Freight:** Compare the counts of the bill of lading to what you actually receive. Any exception must be noted on the carriers delivery receipt. Failure to note any exception at this time will result in the carrier denying your claim.

**Damage of Freight:** Damage to goods received must be noted on the carrier's delivery receipt before the driver leaves the place of delivery. Ask the driver for claim forms. If the driver does not have any forms, call the carrier and request claim forms be mailed to you. Generally, if the damage to the product exceeds \$500.00, the carrier must be called for an inspection. Salvage must be held for the carrier (Very important).

**Concealed Damage:** If goods arrive in apparently good condition, but there is concealed damage, contact the carrier and ask for the goods to be inspected. Keep the product and the packaging material until they have been inspected. A claim needs to be filed with the carrier.

**Returned Goods:** No equipment may be returned without the advance written approval of an authorized Streater representative. Only stock catalog items may be returned within 60 days of original delivery and items must be in unused condition. A handling and restocking charge of 20 percent of net price will be assessed on all returns. Buyer will forward all returns to Streater freight prepaid and all items must be properly packaged.

**Warranty:** Streater warrants to original purchaser that the products it manufactures shall be free from defects in material and workmanship and will conform to applicable specifications, drawings, samples, and descriptions. This warranty shall extend for a period of one year from date of delivery to original purchaser for use. Streater, at its option, may repair or replace any products which, upon Streater's inspection, prove to be defective. Except as set forth herein:

**THERE ARE NO WARRANTIES, EXPRESS OR IMPLIED, INCLUDING THE IMPLIED WARRANTY OF MERCHANTABILITY. UNDER NO CIRCUMSTANCES SHALL STREATER BE LIABLE FOR ANY CONSEQUENTIAL DAMAGES INCURRED BY ORIGINAL PURCHASER AS A RESULT OF STREATER'S PERFORMANCE UNDER THIS ORDER.**



# CUSTOMER DIRECTED MOVE-OUTS

Customer requested changes to ship dates are subject to approval by Streater. Every reasonable effort will be made to accommodate these requests without additional charges to the customer. However, customer requested move-outs within five (5) working days of the scheduled ship date will be subject to the following:

## 1. Surcharge

- A. Orders scheduled for picking, packing and loading, but not yet worked on by the warehouse:  
LTL orders (less than a full semi-trailer load) will be assessed 5% of the net selling price of the order as a handling fee - minimum \$50/maximum \$250
  
- B. Trailer-load sized order assessment will be determined by Vice President of Sales or Vice President of Manufacturing.
  
- C. Jobs picked and sitting on loading dock, but not yet loaded:
  - LTL orders will be assessed 10% of the net selling price of the order as a handling fee - minimum \$100/maximum \$500.
  - Trailer-load sized order: load trailer, invoice customer and charge customer the storage charge for each trailer.
  - For orders in process of being loaded, the assessment would be the same as the bullet above.
  - There is a 20% restocking charge if it is necessary to unload a trailer.

# UPRITE LOADING



Uprite loading is the vertical load, *measured in pounds*, that can be applied on any uprite. Each uprite bears **ONE HALF OF THE LOAD OF EACH SHELF THAT IT SUPPORTS.**

**MAXIMUM UPRITE LOAD IS 4,500 POUNDS  
...DO NOT EXCEED!**

FRONT VIEW

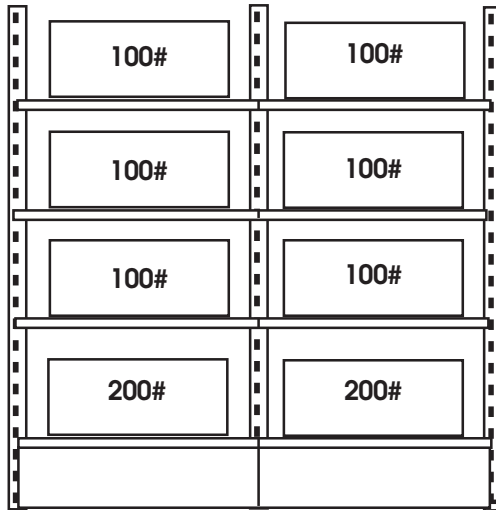

500 lbs. *plus* 500 lbs. = 1000 lbs.  
1000 lbs. ÷ 2 = 500 lb. uprite load  
on center uprite

TOP VIEW OF ISLAND SECTIONS

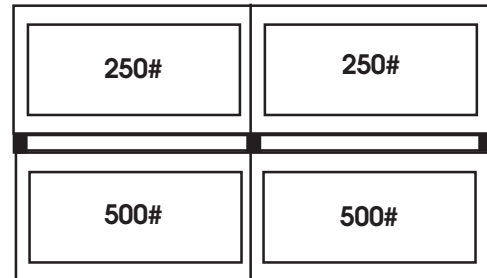

750 lbs. *plus* 750 lbs. = 1500 lbs.  
1500 lbs. ÷ 2 = 750 lb. uprite load  
on center uprite

TOP VIEW OF WALL SECTIONS

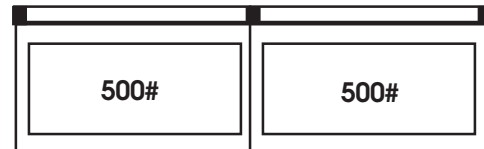

500 lbs. *plus* 500 lbs. = 1000 lbs.  
1000 lbs. ÷ 2 = 500 lb. uprite load  
on center uprite

## LOAD LIMITS OF MILLENNIUM FIXTURES AS MEASURED IN INCH/LBS

| FIXTURE TYPE             | LOAD LIMIT         |                    |
|--------------------------|--------------------|--------------------|
|                          | Standard Base      | Low Base           |
| 36" thru 72" high units  | 15,000 inch/pounds | 12,000 inch/pounds |
| 78" thru 120" high units | 12,000 inch/pounds | 12,000 inch/pounds |



## PRODUCT SAFETY

Offset loading is measured in inch/pounds and represents the bending load at the connection of the base bracket and the upright. To determine if you exceed the load limit of the fixture.....take the difference between the larger inch/lb. calculations on one side of the fixture and the inch/lb. calculations on the other. **THIS DIFFERENCE CANNOT EXCEED 15,000 INCH/LBS. FOR STANDARD BASE ON UNITS 36" THROUGH 72" HIGH AND 12,000 INCH/LBS. FOR LOW BASE ... OR 12,000 INCH/LBS. FOR STANDARD BASE ON UNITS 78" THROUGH 120" HIGH AND 12,000 INCH/LBS. FOR LOW BASE.**

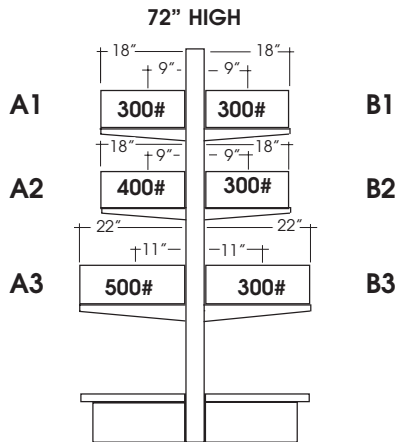

**EVENLY LOADED SHELVES ON ISLANDS**

Divide each shelf depth by 2. Multiply times weight on shelf to determine individual shelf inch/lbs. load

**A1**  $18" \div 2" = 9" \times 300 \text{ lbs. or } 2,700 \text{ inch/lbs.}$

**A2**  $18" \div 2" = 9" \times 400 \text{ lbs. or } 3,600 \text{ inch/lbs.}$

**A3**  $22" \div 2" = 11" \times 500 \text{ lbs. or } 5,500 \text{ inch/lbs.}$

**Side A TOTAL 11,800 inch/lbs.**

**B1**  $18" \div 2" = 9" \times 300 \text{ lbs. or } 2,700 \text{ inch/lbs.}$

**B2**  $18" \div 2" = 9" \times 300 \text{ lbs. or } 2,700 \text{ inch/lbs.}$

**B3**  $22" \div 2" = 11" \times 300 \text{ lbs. or } 3,300 \text{ inch/lbs.}$

**Side B TOTAL 8,700 inch/lbs.**

Subtract **B** from **A**:  
 $11,800 \text{ inch/lbs.}$   
 $-8,700 \text{ inch/lbs.}$   
 $3,100 \text{ inch/lbs.}$

**SAFE! 3,100 INCH/LBS. DOES NOT EXCEED FIXTURE LOAD LIMIT**

**EVENLY LOADED SHELVES ON WALL UNITS**

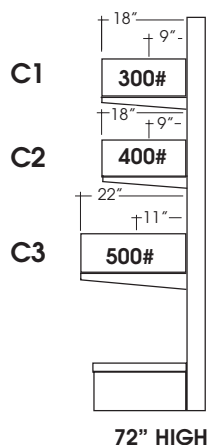

Divide each shelf depth by 2. Multiply times weight on shelf to determine individual shelf inch/lbs. load

**C1**  $18" \div 2" = 9" \times 300 \text{ lbs. or } 2,700 \text{ inch/lbs.}$

**C2**  $18" \div 2" = 9" \times 400 \text{ lbs. or } 3,600 \text{ inch/lbs.}$

**C3**  $22" \div 2" = 11" \times 500 \text{ lbs. or } 5,500 \text{ inch/lbs.}$

**Side C TOTAL 11,800 inch/lbs.**

**SAFE! 11,800 INCH/LBS. DOES NOT EXCEED FIXTURE LOAD LIMIT**

# FRONT LOADED SHELVES



**IMPORTANT!**.....Front loaded shelves create the most likely situation for exceeding the fixture loading capacities. Compare the increases in inch/lb. loadings of front loaded shelves over evenly loaded shelves, **PARTICULARLY ON WALL SECTIONS!**

A front loaded shelf is one that has a void between the back panel and the merchandise. Take one half of the loaded area dimension plus the gap dimension at back and multiply times weight on shelf in order to determine individual inch/lb. load.

- D1** 7" + 4" = 11" x 300 lbs. or 3,300 inch/lbs.
  - D2** 7" + 4" = 11" x 400 lbs. or 4,400 inch/lbs.
  - D3** 9" + 4" = 13" x 500 lbs. or 6,500 inch/lbs.
- Side D TOTAL** 14,200 inch/lbs.

- E1** 6" + 6" = 12" x 300 lbs. or 3,600 inch/lbs.
  - E2** 6" + 6" = 12" x 300 lbs. or 3,600 inch/lbs.
  - E3** 8" + 6" = 14" x 300 lbs. or 4,200 inch/lbs.
- Side E TOTAL** 11,400 inch/lbs.

Subtract **E** from **D**:      14,200 inch/lbs.  
                                       -11,400 inch/lbs.  
                                       2,800 inch/lbs.

**SAFE! 2,800 INCH/LBS. DOES NOT EXCEED FIXTURE LOAD LIMIT**

## FRONT LOADED SHELVES ON ISLANDS

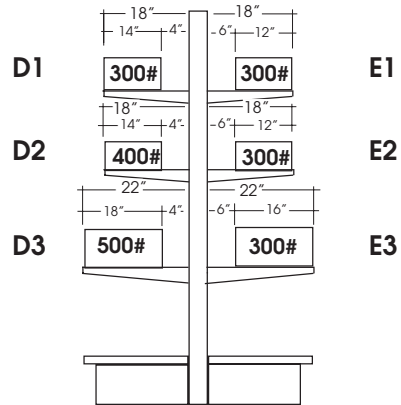

## FRONT LOADED SHELVES ON WALL UNITS

A front loaded shelf is one that has a void between the back panel and the merchandise. Take one half of the loaded area dimension plus the gap dimension at back and multiply times weight on shelf in order to determine individual inch/lb. load.

- F1** 5" + 8" = 13" x 300 lbs. or 3,900 inch/lbs.
  - F2** 5" + 8" = 13" x 400 lbs. or 5,200 inch/lbs.
  - F3** 7" + 8" = 15" x 500 lbs. or 7,500 inch/lbs.
- Side F TOTAL** 16,600 inch/lbs.

**UNSAFE! 16,600 INCH/LBS. EXCEEDS FIXTURE LOAD LIMIT !**

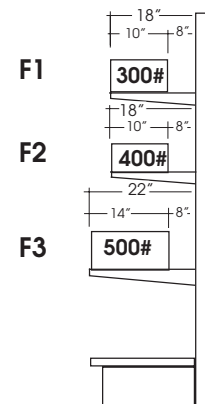

# SPECIFICATIONS

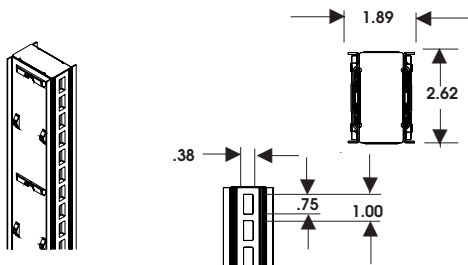

**uprite**

- nominal heights of 42", 54", 60", 72", 84", 96",
- actual heights of uprights 41.92", 53.92", 59.92", 71.92", 83.92", 95.92",
- 18 ga. CRS (side plates), 7 ga. HR (slotted channel)
- rolled & welded construction, factory installed levelers
- painted finish

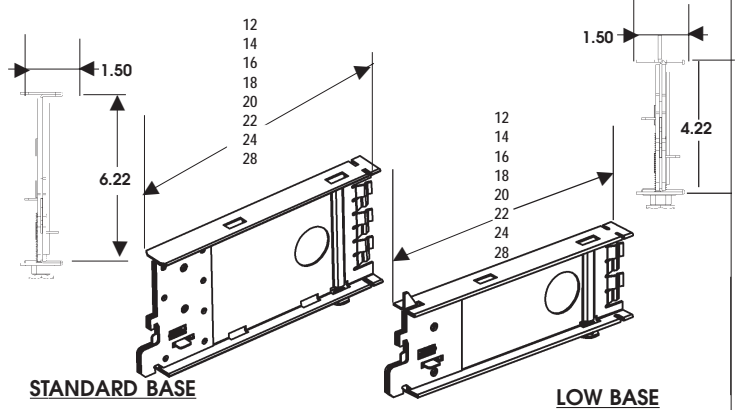

**STANDARD BASE**

**LOW BASE**

**base bracket**

- nominal lengths of 12", 14", 16", 18", 20", 22", 24", 28"
- 10 ga. HR (gusset hooks), 18 ga. CRS (side plates)
- rolled and welded construction
- painted finish
- leveler installed at factory

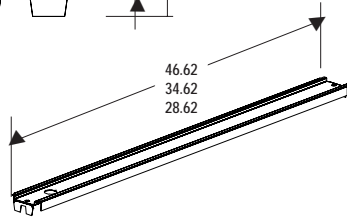
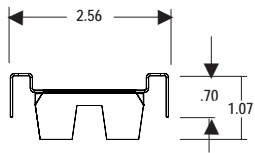

**top rail**

- nominal lengths of 30", 36" & 48"
- 20 ga. CRS
- painted finish

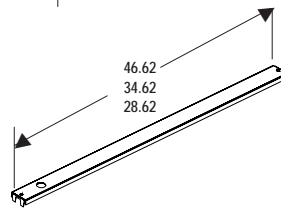
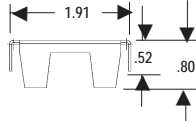

**center rail**

- nominal lengths of 30", 36" & 48"
- 20 ga. CRS
- painted finish

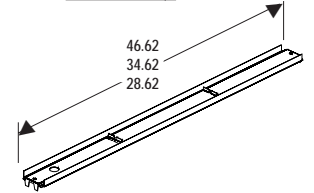
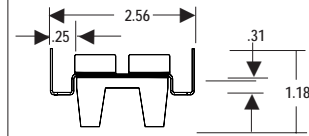

**bottom rail**

- nominal lengths of 30", 36" & 48"
- 20 ga. CRS
- painted finish

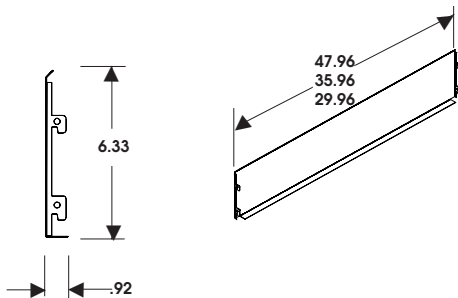

**flush base**

- nominal lengths of 30", 36" & 48"
- 20ga. CRS
- painted finish

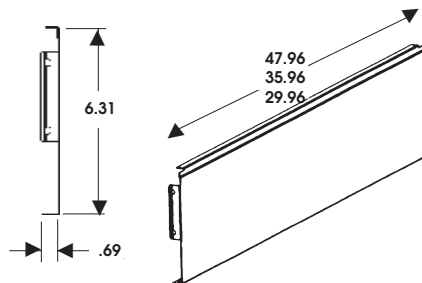

**base front**

- nominal lengths of 30", 36" & 48"
- 18ga. CRS
- painted finish

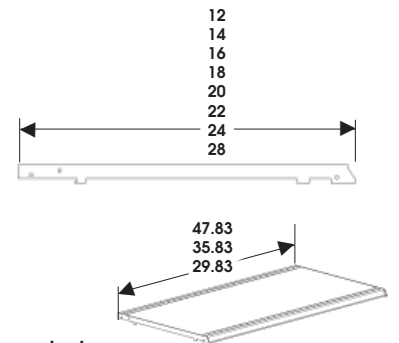

**base deck**

- nominal widths of 30", 36" & 48"
- 23ga. pan & hat, 16ga. end plate
- rolled-in ticket moulding, painted finish
- welded end plates & reinforcing hat sections

# SPECIFICATIONS

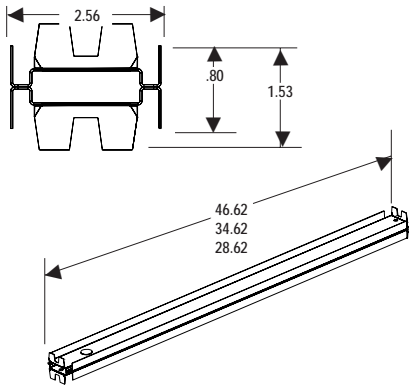

## splicer rail

- nominal lengths of splicer rail: 30", 36" & 48"
- 20ga. CRS
- painted finish

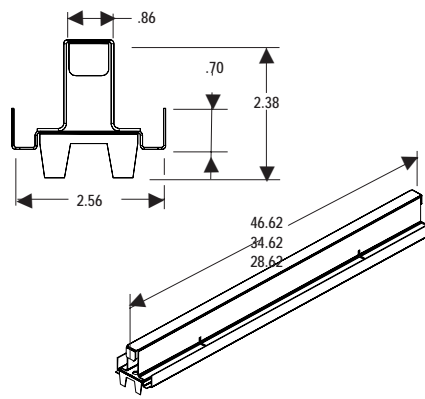

## reinforced bottom rail

- nominal lengths of reinforced bottom rail: 30", 36", 48"
- 13 gauge rolled high strength steel
- painted finish

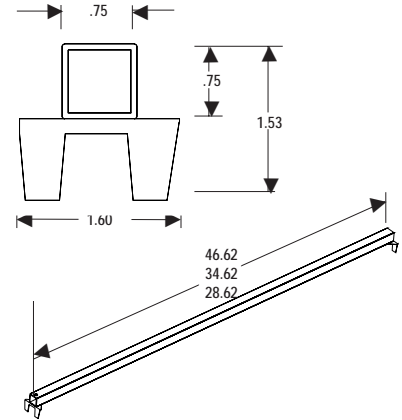

## slatwall center rail

- nominal lengths of slatwall center rail 30", 36", 48"
- 20ga. CRS
- painted finish

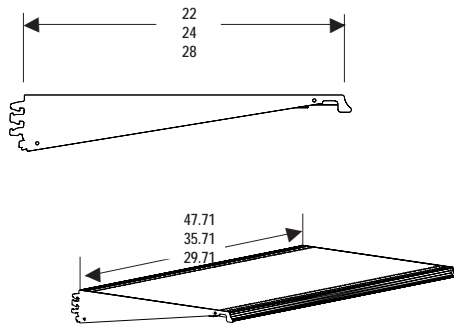

## 3-position heavy duty shelf

- nominal widths of 36" and 48"
- 23 ga. pan & hat
- 11 ga. high strength side brackets
- textured painted finish

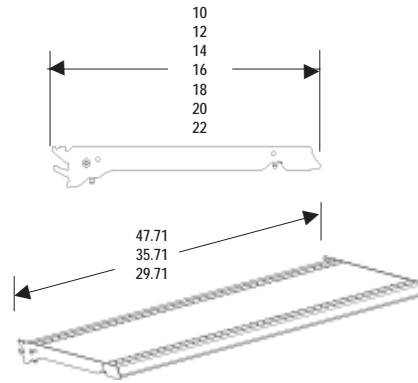

## 4-position shelf

- nominal widths of 30", 36" and 48"
- 23ga. pan & hat, 11ga. HR high strength side brackets
- textured painted finish

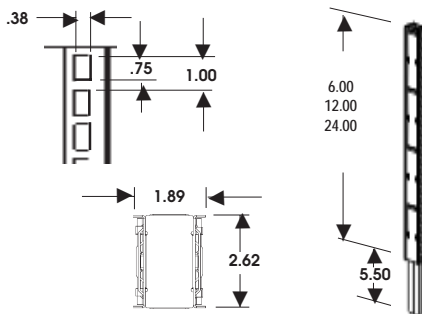

## extender standard

- nominal heights of extenders 6", 12", 24"
- 18 ga. CRS steel (side plates), 7 ga. HR (slotted channel)
- painted finish

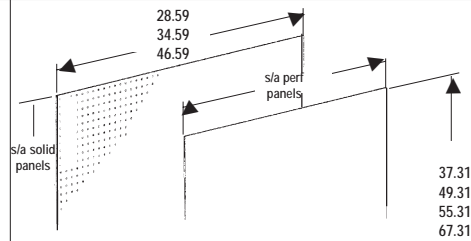

## hardboard back panels

- nominal widths of 30", 36" & 48"
- nominal heights of 42", 54", 60", 72", 84", 96"
- heights over 72" require 2-piece back panels
- ¼", perforated or solid
- perforations ¼" diameter, 1" o.c.
- painted one side, baked acrylic enamel

# PRODUCT SAFETY INFORMATION

- Fixtures should be installed and leveled in accordance with installation instructions.
- All loading warnings as expressed in installation instructions must be observed.
- Damaged components should not be used.
- All components must be securely installed in proper slots and perforations.
- Components should only be used as recommended.
- Shelves or hooks must **never** extend past the base deck.
- Trim is required on uprights and base brackets.
- Do not attempt to move assembled shelving systems. Shelves and components should not be rearranged while merchandised.
- Shelves and components should be installed or rearranged only under the supervision of trained personnel.
- Do not install shelves on the side of a fixture with no base brackets.
- No one should be allowed to climb or stand on shelving.
- Streater can warrant its products only when used with Streater manufactured or supplied components.
- All fixtures should be assembled and arranged such that sharp or pointed surfaces are not exposed to employees or shoppers.
- All end merchandisers that will be used with shelves or peghooks must include a contour end deck to direct traffic away from protrusions.
- To avoid top heavy free-standing wall sections that could possibly tip over, the following base depth to upright height must be utilized:

| deck depth  | maximum unanchored upright height |
|-------------|-----------------------------------|
| 12,14       | 54                                |
| 16          | 72                                |
| 18          | 84                                |
| 20,22,24,28 | 96                                |

# MILLENNIUM DISPLAY COMPONENTS

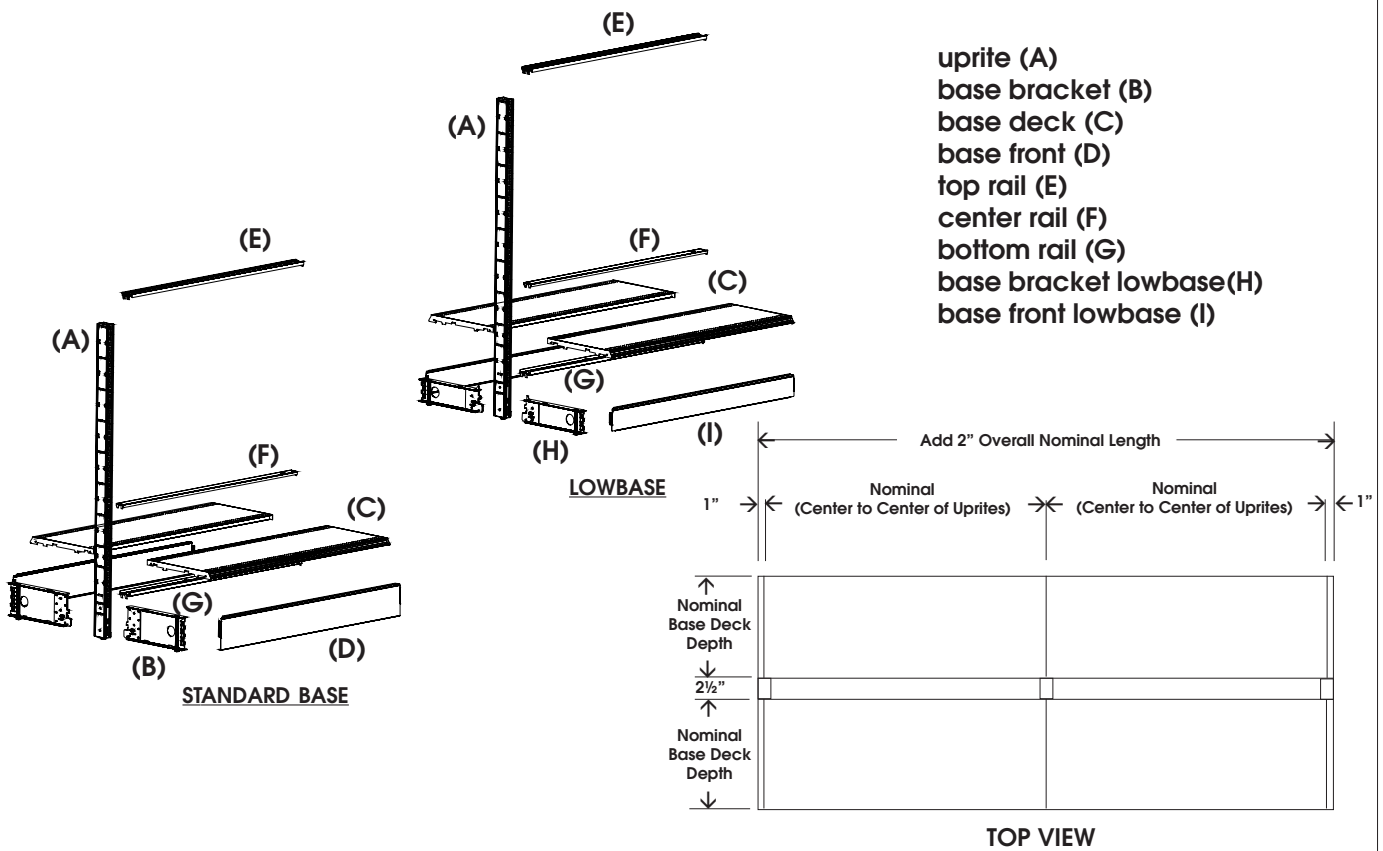

## standard base sections

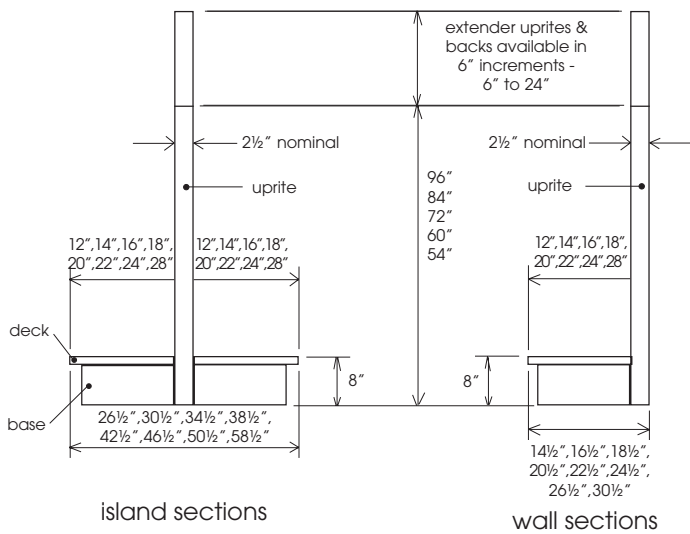

**NOTE: All dimensions are nominal. If exact dimensions are required, please contact the factory.**

## low base sections

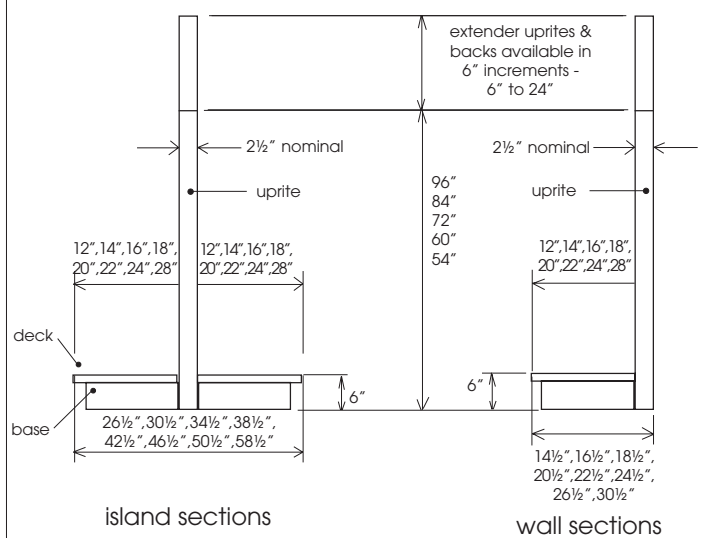

**NOTE: All dimensions are nominal. If exact dimensions are required, please contact the factory.**



# MILLENNIUM ISLAND SECTIONS

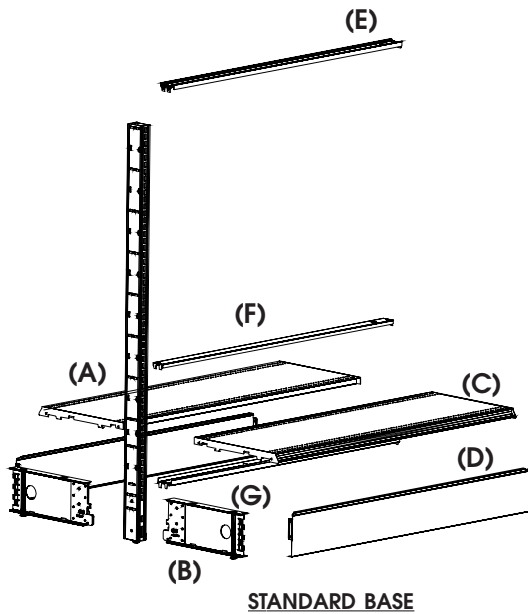

**STANDARD BASE**

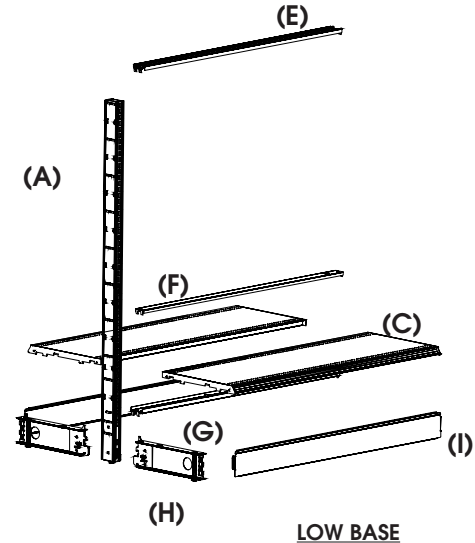

**LOW BASE**

- island shelving units consist of:
  - 1 - uprite (A)
  - 2 - base brackets (B)
  - 2 - base decks (C)
  - 2 - base fronts (D)
  - 1 - top rail (E)
  - 1 - center rail (F)
  - 1 - bottom rail (G)
  - 2 - base brackets low base (H)
  - 2 - base fronts low base (I)
  - 2 - uprite covers (J)
  - 2 - standard base bracket covers (K)
  - 2 - lowbase base bracket covers (L)

- All internal (hidden) parts color (03) variant.
- Base front is color (25) black.
- Uprites, decks and back panels paint colors as shown on paint chart

## island end

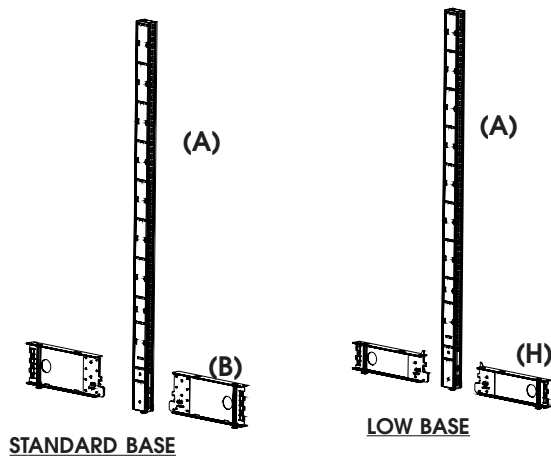

**STANDARD BASE**

**LOW BASE**

The island end package completes the island shelving run using the following parts:

- 1 - uprite
- 2 - base brackets

## island trim

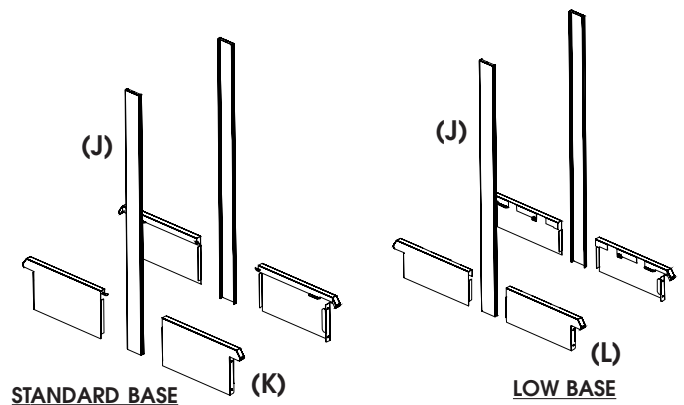

**STANDARD BASE**

**LOW BASE**

The island end trim package protects customers and employees and must be used in all situations. The kit includes the following parts:

- 2 - uprite covers
- 2 pr - base bracket covers

# WALL SECTIONS

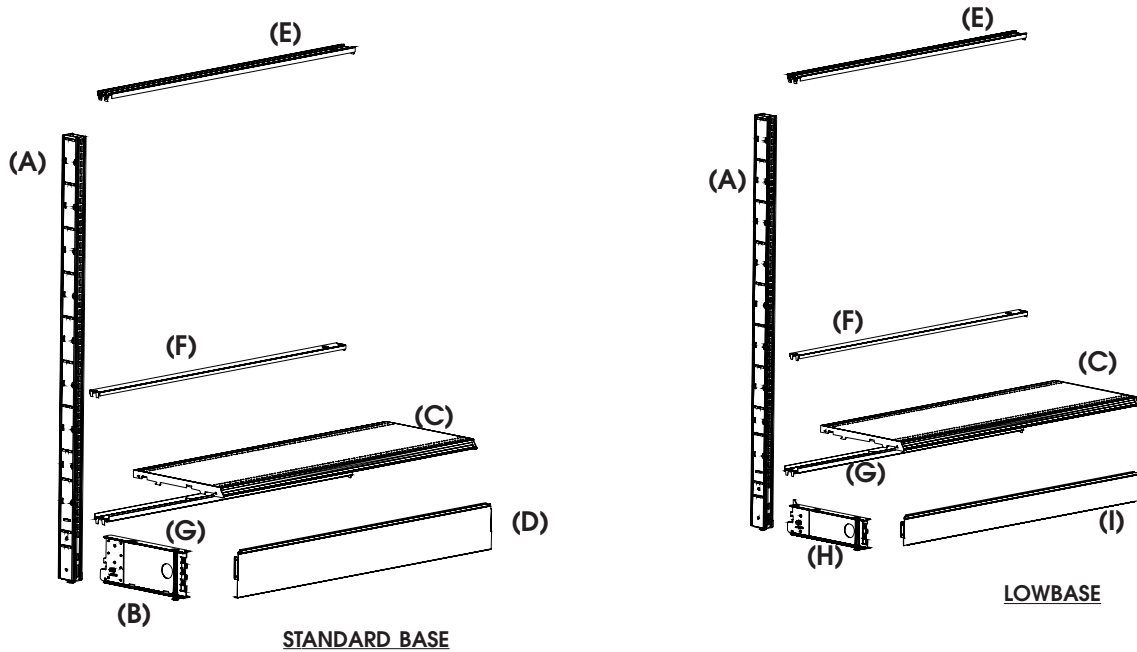

- wall units consist of: 1 - uprite (A)
- 1 - base bracket (B)
- 1 - base deck (C)
- 1 - base front (D)
- 1 - top rail (E)
- 1 - center rail (F)
- 1 - bottom rail (G)
- 1 - base bracket low base (H)
- 1 - base front low base (I)
- 1 - standard base cover (K)
- 1 - low base base cover (L)

- All internal (hidden) parts are color (03) variant.
- Base front is color (25) black.

## wall end

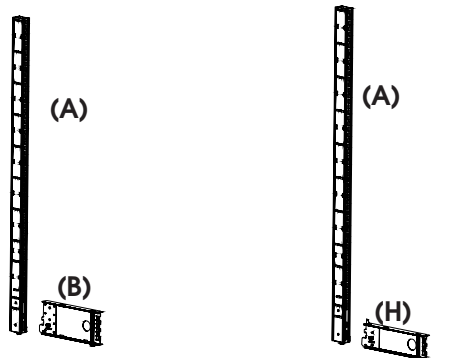

**STANDARD BASE**

**LOW BASE**

The wall end package completes the wall shelving run using the following parts:

- 1 - uprite
- 1 - base bracket

## wall trim

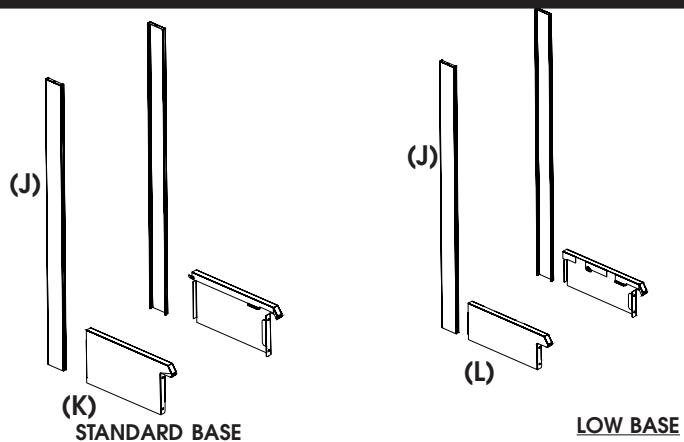

**STANDARD BASE**

**LOW BASE**

The wall end trim package protects customers and employees and must be used in all situations. The kit includes the following parts:

- 2 - uprite covers
- 1 pr - base bracket covers

# COMPONENT PARTS

## uprights



| height | part number | wt.  |
|--------|-------------|------|
| 42     | 08800-2151  | 11.8 |
| 54     | 08800-2153  | 15.1 |
| 60     | 08800-2154  | 16.7 |
| 72     | 08800-2155  | 19.9 |
| 84     | 08800-2157  | 22.8 |
| 96     | 08800-2158  | 26.3 |

- Used on all wall & island sections
- All steel, welded construction, 3/16" face, channel
- Slotted 1" on center
- Includes leveler
- Upright caps included on all uprights 42"- 60" high
- See color chart for available paint colors

## upright trim

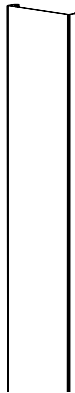

- Vinyl prefinished trim available in:  
**25 - black**      **15 - white**  
**PP - platinum plus**    **KM - dove gray**

| height                                | part number | wt. |
|---------------------------------------|-------------|-----|
| <b>prefinished uprightrail trim</b>   |             |     |
| 42                                    | 08601-2219  | 0.4 |
| 54                                    | 08601-2220  | 0.5 |
| 60                                    | 08601-2221  | 0.6 |
| 72                                    | 08601-2222  | 0.7 |
| 84                                    | 08601-2223  | 0.8 |
| 96                                    | 08601-2224  | 0.9 |
| <b>painted steel uprightrail trim</b> |             |     |
| 42                                    | 08445-3304  | 1.4 |
| 54                                    | 08445-3306  | 1.8 |
| 60                                    | 08445-3307  | 2.2 |
| 72                                    | 08445-3309  | 2.7 |
| 84                                    | 08445-3311  | 3.1 |
| 96                                    | 08445-3313  | 3.5 |

- Snaps onto first and last upright to finish a run
- Steel upright covers available in any optional paint color, see color chart

## extender upright

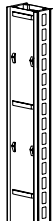

| height | part number | wt. |
|--------|-------------|-----|
| 6      | 08800-1775  | 3.0 |
| 12     | 08800-1776  | 4.5 |
| 24     | 08800-1778  | 7.5 |

- Standard upright, 1" slotting on center, with factory installed connector
- See color chart for available paint colors

## extender upright trim

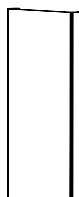

- Vinyl prefinished trim available in:  
**25 - black**      **15 - white**  
**PP - platinum plus**    **KM - dove gray**

| height                                | part number | wt. |
|---------------------------------------|-------------|-----|
| <b>prefinished uprightrail trim</b>   |             |     |
| 6                                     | 08601-2065  | 0.1 |
| 12                                    | 08601-2066  | 0.1 |
| 24                                    | 08601-2068  | 0.2 |
| <b>painted steel uprightrail trim</b> |             |     |
| 6                                     | 08445-2978  | .2  |
| 12                                    | 08445-2979  | .4  |
| 24                                    | 08445-2980  | .8  |

# COMPONENT PARTS

## std base bracket

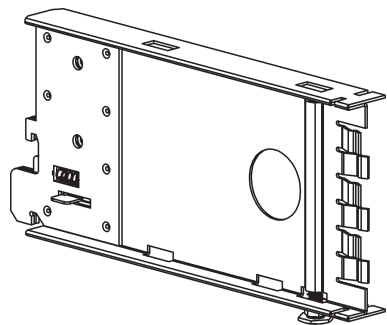

| depth | part number | wt. per 5 |
|-------|-------------|-----------|
| 12    | 08704-2297  | 20        |
| 14    | 08704-2298  | 22        |
| 16    | 08704-2299  | 24        |
| 18    | 08704-2300  | 27        |
| 20    | 08704-2301  | 29        |
| 22    | 08704-2302  | 31        |
| 24    | 08704-2303  | 33        |
| 28    | 08704-2305  | 37        |

- Installs easily into bottom of uprite
- Actual bracket length is 3" less than deck
- Bracket height 6.25"
- **Must be ordered in quantities of 5**
- Includes leveler
- Spring loaded locking key
- **Color: 03-variant only**

## low base bracket

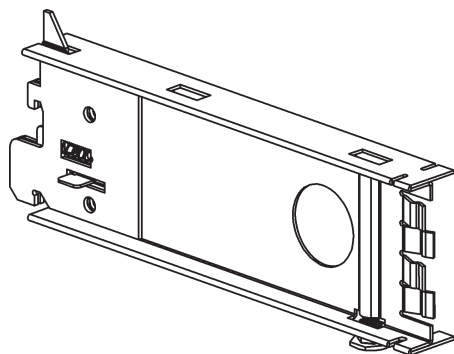

| depth | part number | wt. per 5 |
|-------|-------------|-----------|
| 12    | 08704-2234  | 18        |
| 14    | 08704-2235  | 19        |
| 16    | 08704-2236  | 21        |
| 18    | 08704-2237  | 23        |
| 20    | 08704-2238  | 24        |
| 22    | 08704-2239  | 26        |
| 24    | 08704-2240  | 28        |
| 28    | 08704-2242  | 33        |

- Installs easily into bottom of uprite
- Actual bracket length is 3" less than deck
- Bracket height 4.25"
- **Must be ordered in quantities of 5**
- Includes leveler
- Spring loaded locking key
- **Color: 03-variant only**

## std base bracket trim

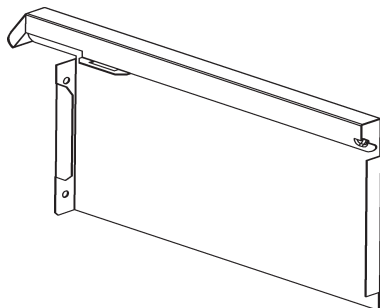

| depth | part number | wt. |
|-------|-------------|-----|
| 12    | 08403-8102  | 1.5 |
| 14    | 08403-8103  | 1.7 |
| 16    | 08403-8104  | 1.9 |
| 18    | 08403-8105  | 2.1 |
| 20    | 08403-8106  | 2.3 |
| 22    | 08403-8107  | 2.5 |
| 24    | 08403-8108  | 2.7 |
| 28    | 08403-8110  | 3.1 |

- Steel construction
- Specify left or right hand
- **Color: 25 black only**

## low base bracket trim

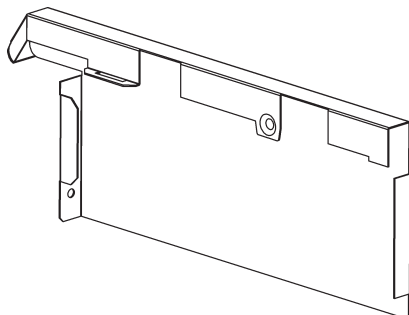

| depth | part number | wt. |
|-------|-------------|-----|
| 12    | 08403-8186  | 0.9 |
| 14    | 08403-8187  | 1.1 |
| 16    | 08403-8188  | 1.2 |
| 18    | 08403-8189  | 1.4 |
| 20    | 08403-8190  | 1.5 |
| 22    | 08403-8191  | 1.7 |
| 24    | 08403-8192  | 1.8 |
| 28    | 08403-8194  | 2.1 |

- Steel construction
- Specify left or right hand
- **Color: 25 black only**

# COMPONENT PARTS

## top rail

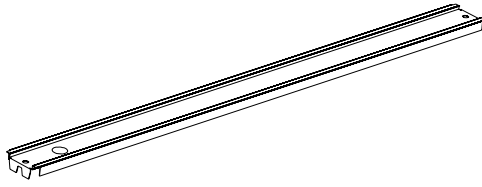

| width | part number | wt. per 20 |
|-------|-------------|------------|
| 30    | 08403-5765  | 30         |
| 36    | 08403-5766  | 34         |
| 48    | 08403-5767  | 46         |

- Caps top of unit
- See color chart for available paint colors
- **Must be ordered in quantities of 20**

## center rail

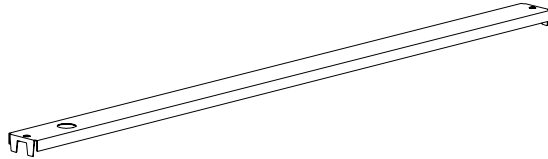

| width | part number | wt. per 20 |
|-------|-------------|------------|
| 30    | 08403-5773  | 20         |
| 36    | 08403-5774  | 22         |
| 48    | 08403-5775  | 31         |

- Spaces uprights & reinforces back panels
- **Color: 03-variant only**
- **Must be ordered in quantities of 20**

## bottom rail

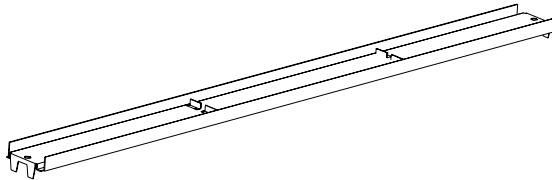

| width | part number | wt. per 20 |
|-------|-------------|------------|
| 30    | 08403-5781  | 30         |
| 36    | 08403-5782  | 34         |
| 48    | 08403-5783  | 46         |

- Supports back panels & spaces uprights
- **Color: 03-variant only**
- **Must be ordered in quantities of 20**

## splicer rail



| depth | part number | wt. per 10 |
|-------|-------------|------------|
| 30    | 08403-7148  | 30         |
| 36    | 08403-7149  | 34         |
| 48    | 08403-7150  | 46         |

- Used as splicer for 2-piece back panels
- See color chart for available paint colors
- **Must be ordered in quantities of 10**

## slatwall center rail

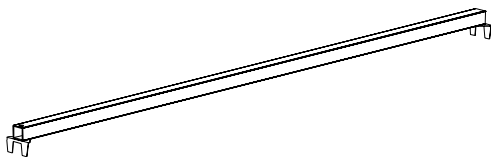

| depth | part number | wt. |
|-------|-------------|-----|
| 36    |             | 2.0 |
| 48    |             | 2.6 |

- Replaces center rail when slatwall backs are used
- Two required at heights of 78" and above
- Order a slatwall support clip when slatwall panel is used on one side of unit and solid or perf panel is used on other side
- **Color: 03-variant only**

## reinforced bottom rail

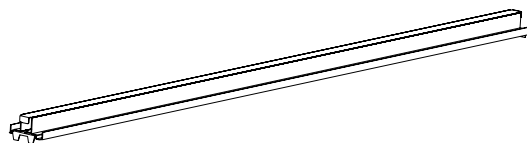

| depth | part number | wt. |
|-------|-------------|-----|
| 36    |             | 4.0 |
| 48    |             | 5.3 |

- Replaces bottom rail when slatwall backs are used
- **Color: 03-variant only**

# COMPONENT PARTS

## support clip

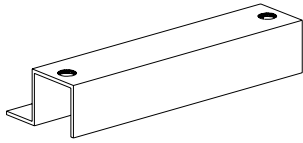

- Used on slatwall center rail when island unit has slatwall back panel on one side and solid or perf back panel on the opposite side
- Use one per unit
- **Color: 03 - variant only**

## flush base

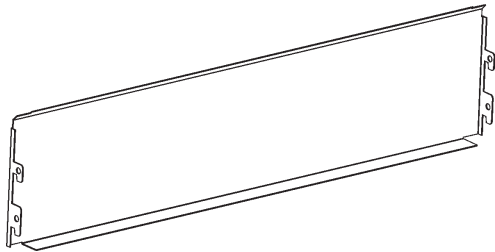

| width | part number | wt.<br>per 10 |
|-------|-------------|---------------|
| 30    | 08403-8147  | 39            |
| 36    | 08403-8148  | 45            |
| 48    | 08403-8149  | 67            |

- Hooks into uprite to fill gap between bottom rail and floor
- For use with standard base or low base
- **Color: 25 - black only**
- **Must be ordered in quantities of 10**

## std base front

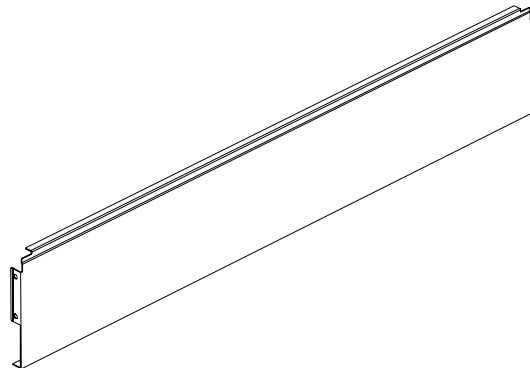

| width | part number | wt.<br>per 10 |
|-------|-------------|---------------|
| 30    | 08403-6549  | 34            |
| 36    | 08403-6550  | 38            |
| 48    | 08403-6551  | 50            |

- Floating feature allows base front to be flush with floor regardless of the levelness of flooring
- Height 6"
- Snaps into base brackets
- Can be removed without removing base deck
- **Color: 25 black only**
- **Must be ordered in quantities of 10**

## low base front

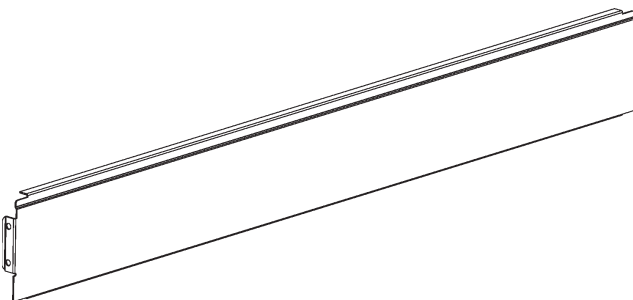

| width | part number | wt.<br>per 10 |
|-------|-------------|---------------|
| 30    | 08403-8002  | 25            |
| 36    | 08403-8003  | 28            |
| 48    | 08403-8004  | 39            |

- Floating feature allows base front to be flush with floor regardless of the levelness of flooring
- Height 4"
- Snaps into base brackets
- Can be removed without removing base deck
- **Color: 25 - black only**
- **Must be ordered in quantities of 10**

# COMPONENT PARTS

## std base load easer

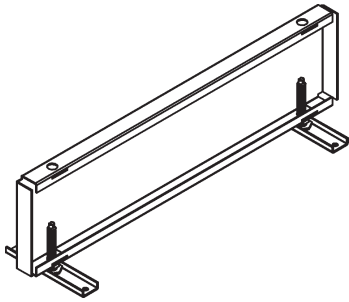

| depth | part number | wt. |
|-------|-------------|-----|
|-------|-------------|-----|

|    |            |     |
|----|------------|-----|
| 22 | 08704-2131 | 3.9 |
|----|------------|-----|

- Placed midway between base brackets to increase capacity of deck by 500 lbs.
- Levelers shipped loose
- Height 6"
- Galvanized

## low base load easer

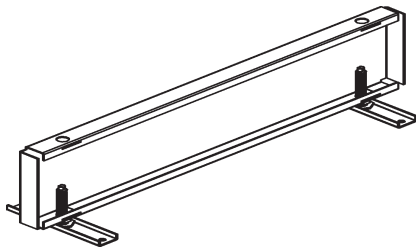

| depth | part number | wt. |
|-------|-------------|-----|
|-------|-------------|-----|

|    |            |     |
|----|------------|-----|
| 22 | 08704-2130 | 3.3 |
|----|------------|-----|

- Placed midway between base brackets to increase capacity of deck by 500 lbs.
- Levelers shipped loose
- Height 5"
- Galvanized

## upright cap

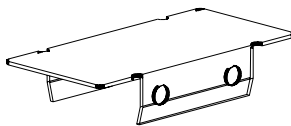

| size | part number | wt. per 10 |
|------|-------------|------------|
|------|-------------|------------|

|   |            |     |
|---|------------|-----|
| - | 08403-7242 | 1.3 |
|---|------------|-----|

- Caps top of uprite
- See color chart for paint colors available
- **Must be ordered in quantities of 10**

## upright anchor

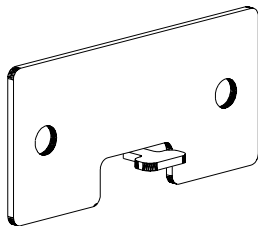

center tie

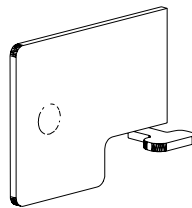

end tie

| anchor type | part number | wt. per 20 |
|-------------|-------------|------------|
|-------------|-------------|------------|

|         |            |     |
|---------|------------|-----|
| ctr tie | 08415-9987 | 6.1 |
| end tie | 08415-9988 | 3.7 |

- Wall mount bracket aids in lagging uprites to structural walls where required. Customer provides fasteners appropriate for building material.
- Two brackets required per uprite, one per extender uprite.
- Available in 2 styles: for uprites on the end or uprites within run of wall units.
- **Color: 03 - variant only**
- **Must be ordered in quantities of 20**

## floor anchor

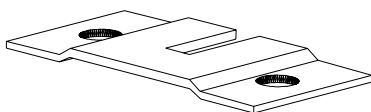

| anchor type | part number | wt. per 20 |
|-------------|-------------|------------|
|-------------|-------------|------------|

|              |            |     |
|--------------|------------|-----|
| anchor plate | 08415-4724 | 4.5 |
|--------------|------------|-----|

- Anchor secures uprite or base bracket leveler leg to floor, using customer-supplied anchor bolts.
- Must be used when shelving unit exceeds a height-to-depth ratio of 6:1.
- **Color: 03 - variant only**
- **Must be ordered in quantities of 10**

# BACK PANELS

## solid backs

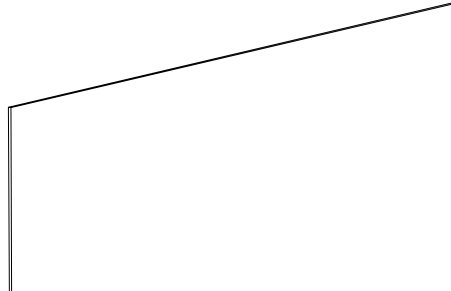

height width part number wt.

|    |    |            |      |
|----|----|------------|------|
| 42 | 30 | 08597-0137 | 7.4  |
| 54 | 30 | 08597-0139 | 9.8  |
| 60 | 30 | 08597-0140 | 11.0 |
| 72 | 30 | 08597-0142 | 13.4 |
| 84 | 30 | 00291-2391 | 15.7 |
| 96 | 30 | 00291-2392 | 18.1 |

|    |    |            |      |
|----|----|------------|------|
| 42 | 36 | 08597-0121 | 9.0  |
| 54 | 36 | 08597-0122 | 11.8 |
| 60 | 36 | 08597-0123 | 13.3 |
| 72 | 36 | 08597-0125 | 16.2 |
| 84 | 36 | 00291-2387 | 19.0 |
| 96 | 36 | 00291-2388 | 21.9 |

|    |    |            |      |
|----|----|------------|------|
| 42 | 48 | 08597-0127 | 12.1 |
| 54 | 48 | 08597-0128 | 16.0 |
| 60 | 48 | 08597-0129 | 17.9 |
| 72 | 48 | 08597-0131 | 21.8 |
| 84 | 48 | 00291-2389 | 25.6 |
| 96 | 48 | 00291-2390 | 29.5 |

### extender backs

|    |    |            |     |
|----|----|------------|-----|
| 6  | 30 | 08597-0067 | 1.2 |
| 12 | 30 | 08597-0068 | 2.3 |
| 24 | 30 | 08597-0070 | 4.7 |

|    |    |            |     |
|----|----|------------|-----|
| 6  | 36 | 08597-0079 | 1.4 |
| 12 | 36 | 08597-0080 | 2.8 |
| 24 | 36 | 08597-0082 | 5.7 |

|    |    |            |     |
|----|----|------------|-----|
| 6  | 48 | 08597-0091 | 1.9 |
| 12 | 48 | 08597-0092 | 3.8 |
| 24 | 48 | 08597-0094 | 7.7 |

- Two required per island section, one per wall section
  - Solid hardboard, painted one side
  - See color chart for paint colors available
- TWO-PIECE BACKS: 84" AND UP ALSO REQUIRES SPLICER RAIL**

# BACK PANELS

## perf backs

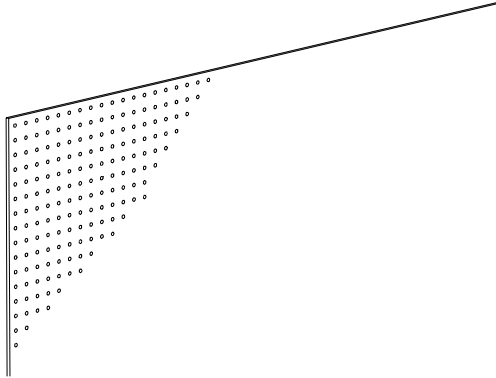

| height | width | part number | wt.  |
|--------|-------|-------------|------|
| 42     | 30    | 08597-0268  | 5.6  |
| 54     | 30    | 08597-0270  | 7.4  |
| 60     | 30    | 08597-0271  | 8.3  |
| 72     | 30    | 08597-0273  | 10.1 |
| 84     | 30    | 00291-2397  | 11.8 |
| 96     | 30    | 00291-2398  | 13.6 |
| 42     | 36    | 08597-0252  | 6.8  |
| 54     | 36    | 08597-0253  | 8.9  |
| 60     | 36    | 08597-0254  | 10.0 |
| 72     | 36    | 08597-0256  | 12.2 |
| 84     | 36    | 00291-2393  | 14.3 |
| 96     | 36    | 00291-2394  | 16.4 |
| 42     | 48    | 08597-0258  | 9.1  |
| 54     | 48    | 08597-0259  | 12.0 |
| 60     | 48    | 08597-0260  | 13.4 |
| 72     | 48    | 08597-0262  | 16.4 |
| 84     | 48    | 00291-2395  | 19.2 |
| 96     | 48    | 00291-2396  | 22.1 |

### extender backs

|    |    |            |     |
|----|----|------------|-----|
| 6  | 30 | 08597-1067 | .9  |
| 12 | 30 | 08597-1068 | 1.7 |
| 24 | 30 | 08597-1070 | 3.5 |
| 6  | 36 | 08597-1079 | 1.1 |
| 12 | 36 | 08597-1080 | 2.1 |
| 24 | 36 | 08597-1082 | 4.3 |
| 6  | 48 | 08597-1091 | 1.4 |
| 12 | 48 | 08597-1092 | 2.9 |
| 24 | 48 | 08597-1094 | 5.8 |

- Two required per island section, one per wall section
- Solid hardboard, painted one side
- Perforated hardboard, 1/4" dia., 1" on center
- See color chart for paint colors available

**TWO-PIECE BACKS: 84" AND UP ALSO REQUIRES SPLICER RAIL**

# BACK PANELS

## slatwall backs

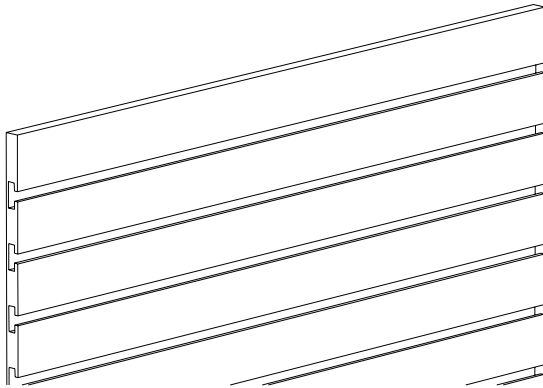

| height | width | part number | wt.  |
|--------|-------|-------------|------|
| 42     | 36    |             | 21.2 |
| 54     | 36    |             | 28.1 |
| 60     | 36    |             | 31.6 |
| 72     | 36    |             | 38.6 |
| 84     | 36    |             | 45.5 |
| 96     | 36    |             | 52.4 |
| 42     | 48    |             | 28.7 |
| 54     | 48    |             | 38.0 |
| 60     | 48    |             | 42.7 |
| 72     | 48    |             | 52.1 |
| 84     | 48    |             | 61.5 |
| 96     | 48    |             | 70.9 |

- Two required per island section, one per wall section
- 3/4" thick multi-density fibreboard, grooved 3" on center
- Baked enamel paint one side
- Slatwall center rail and reinforced bottom rail required (see page 119)
- See color chart for paint colors available

**TWO-PIECE BACKS: 72" AND UP ALSO REQUIRES SPLICER RAIL**

# SHELVES

## std shelf



| depth | width | part number | capacity | wt. per 4 |
|-------|-------|-------------|----------|-----------|
| 10    | 30    | 01465-1030  | 350      | 23.6      |
| 12    | 30    | 01465-1230  | 350      | 30.4      |
| 14    | 30    | 01465-1430  | 350      | 33.6      |
| 16    | 30    | 01465-1630  | 500      | 40.4      |
| 18    | 30    | 01465-1830  | 500      | 43.6      |
| 10    | 36    | 01465-1036  | 500      | 31.6      |
| 12    | 36    | 01465-1236  | 500      | 35.2      |
| 14    | 36    | 01465-1436  | 500      | 38.8      |
| 16    | 36    | 01465-1636  | 500      | 46.8      |
| 18    | 36    | 01465-1836  | 500      | 50.8      |
| 20    | 36    | 01465-2036  | 400      | 54.4      |
| 10    | 48    | 01465-1048  | 500      | 37.6      |
| 12    | 48    | 01465-1248  | 500      | 42.0      |
| 14    | 48    | 01465-1448  | 500      | 51.6      |
| 16    | 48    | 01465-1648  | 500      | 56.4      |
| 18    | 48    | 01465-1848  | 500      | 66.4      |
| 20    | 48    | 01465-2048  | 400      | 70.8      |

- Tip-in style shelf
- Three position shelf - straight and 17° & 30° downslant
- 1 1/4" ticket moulding
- Two rows of perforations 1" o.c front to rear, 1/2" o.c left to right
- Vertically adjustable in 1" intervals
- See chart for capacity of evenly distributed load per shelf
- Weight capacity stated is for shelf in straight position
- See color chart for available paint colors

**MUST BE ORDERED IN 4 PACKS**

## heavy-duty shelf

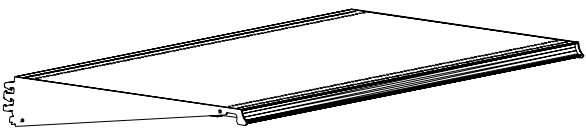

| depth | width | part number | capacity | wt. per 2 |
|-------|-------|-------------|----------|-----------|
| 22    | 36    | 01357-2236  | 600      | 30.4      |
| 24    | 36    | 01357-2436  | 600      | 34.4      |
| 28    | 36    | 01357-2836  | 600      | 40.6      |
| 22    | 48    | 01357-2248  | 600      | 39.4      |
| 24    | 48    | 01357-2448  | 600      | 45.4      |
| 28    | 48    | 01357-2848  | 600      | 50.2      |

- Drop-in style shelf
- Three position shelf - straight and 17° & 30° downslant
- 1 1/4" ticket moulding
- Two rows of perforations 1" o.c front to rear, 1/2" o.c left to right
- Vertically adjustable in 1" intervals
- See chart for capacity of evenly distributed load per shelf
- Weight capacity stated is for shelf in straight position
- See color chart for available paint colors

**MUST BE ORDERED IN 2 PACKS**

# SHELVES

## downslant

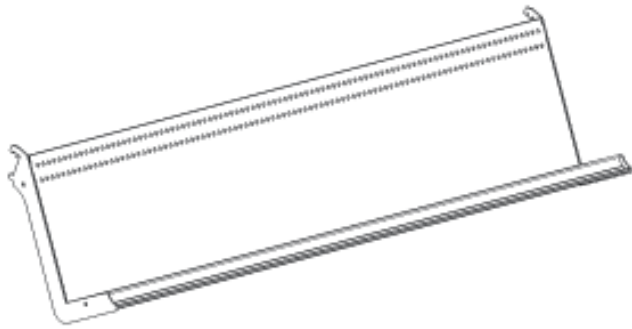

| depth | width | part number | wt. |
|-------|-------|-------------|-----|
| 10    | 36    | 08701-1194  | 5.9 |
| 14    | 36    | 08701-1196  | 7.5 |
| 10    | 48    | 08701-1190  | 7.5 |
| 14    | 48    | 08701-1192  | 9.4 |

- Maximum load capacity of 150lbs
- 1 1/4" ticket moulding
- See color chart for available paint colors

## base deck

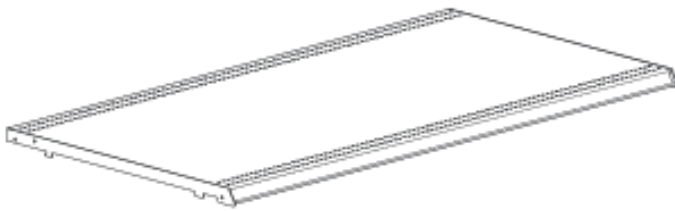

| depth | width | part number | wt.  |
|-------|-------|-------------|------|
| 12    | 30    | 01358-1230  | 5.8  |
| 14    | 30    | 01358-1430  | 6.3  |
| 16    | 30    | 01358-1630  | 7.8  |
| 18    | 30    | 01358-1830  | 8.4  |
| 20    | 30    | 01358-2030  | 9.0  |
| 22    | 30    | 01358-2230  | 10.1 |
| 24    | 30    | 01358-2430  | 11.3 |
| 28    | 30    | 01358-2830  | 13.2 |
| 12    | 36    | 01358-1236  | 6.7  |
| 14    | 36    | 01358-1436  | 7.3  |
| 16    | 36    | 01358-1636  | 9.1  |
| 18    | 36    | 01358-1836  | 9.8  |
| 20    | 36    | 01358-2036  | 10.5 |
| 22    | 36    | 01358-2236  | 11.2 |
| 24    | 36    | 01358-2436  | 13.0 |
| 28    | 36    | 01358-2836  | 15.5 |
| 12    | 48    | 01358-1248  | 8.5  |
| 14    | 48    | 01358-1448  | 10.8 |
| 16    | 48    | 01358-1648  | 11.7 |
| 18    | 48    | 01358-1848  | 14.0 |
| 20    | 48    | 01358-2048  | 14.9 |
| 22    | 48    | 01358-2248  | 15.8 |
| 24    | 48    | 01358-2448  | 18.1 |
| 28    | 48    | 01358-2848  | 19.9 |

- Recommended evenly distributed load capacity:  
600# - 12" thru 22"  
800# - 24" thru 28"
- 1 1/4" ticket moulding
- Two rows of perforations 1" o.c front to rear, 1/2" o.c left to right
- See color chart for available paint colors

# GLASS SHELF/ACCESSORIES

## glass shelf top

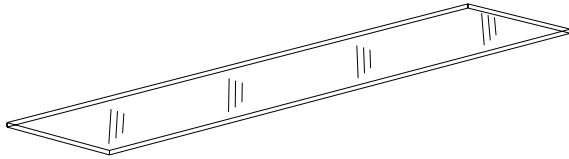

| depth | width | part number | wt. per 4 |
|-------|-------|-------------|-----------|
| 10    | 36    | 16002-1036  | 28.7      |
| 10    | 48    | 16002-1048  | 43.7      |
| 12    | 36    | 16002-1236  | 39.4      |
| 12    | 48    | 16002-1248  | 46.1      |
| 14    | 36    | 16002-1436  | 40.4      |
| 14    | 48    | 16002-1448  | 53.6      |
| 16    | 36    | 16002-1636  | 52.1      |
| 16    | 48    | 16002-1648  | 61.3      |

- ¼" thick, ground edges
- Clear glass only
- **Must be ordered in quantities of 4**

## glass shelf brackets

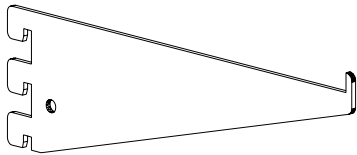

| size | part number | wt. per 8 |
|------|-------------|-----------|
| 10"  | 08401-2167  | 10.3      |
| 12"  | 08401-2168  | 12.1      |
| 14"  | 08401-2169  | 13.8      |
| 16"  | 08401-2170  | 15.6      |

- See color chart for available paint colors
- **Must be ordered in quantities of 8**

## glass shelf support

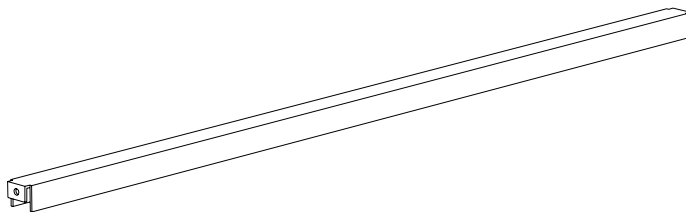

| size | part number | wt. |
|------|-------------|-----|
| 36"  | 08445-0499  | 3.1 |
| 48"  | 08445-0500  | 4.4 |

- Supports up to 75 lbs.
- See color chart for available paint colors

## glass shelf clips

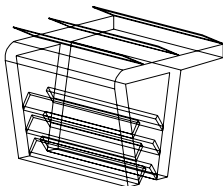

| size | part number | wt. per 16 |
|------|-------------|------------|
| -    | 08302-1660  | 0.3        |

- Fit on all glass shelf brackets to cushion and stabilize the shelf
- Two clips required per bracket
- Clear vinyl

# HEAVY-DUTY WIRE BASKETS

## endless wire baskets

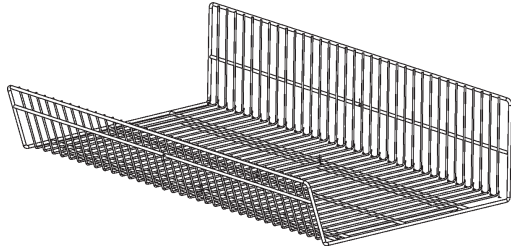

| depth | width | part number | wt.  |
|-------|-------|-------------|------|
| 12    | 36    | 08303-1935  | 8.1  |
| 12    | 48    | 08303-1928  | 9.8  |
| 14    | 36    | 08303-1934  | 8.5  |
| 14    | 48    | 08303-1927  | 10.8 |
| 16    | 36    | 08303-1933  | 9.0  |
| 16    | 48    | 08303-1926  | 11.5 |

- 8½" high back, 6" high sloped front
- Order dividers separately (see next page)
- Brackets must be ordered separately (see below)
- Ticket moulding available for 48" basket
- **Color 81 - chrome finish only**
- **Weight capacity on all sizes is 300 lbs., uniform load**

## reversible wire shelf

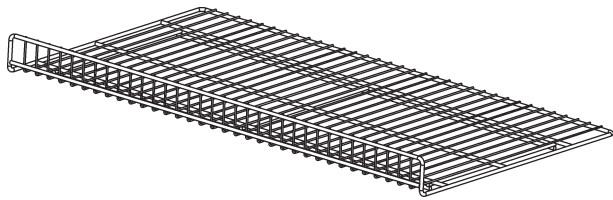

| depth | width | part number | wt. |
|-------|-------|-------------|-----|
| 18    | 36    | 08303-1959  | 6.6 |
| 18    | 48    | 08303-1952  | 8.2 |
| 20    | 36    | 08303-1958  | 6.7 |
| 20    | 48    | 08303-1951  | 8.4 |
| 22    | 36    | 08303-1957  | 6.9 |
| 22    | 48    | 08303-1950  | 8.6 |
| 24    | 36    | 08303-1956  | 7.0 |
| 24    | 48    | 08303-1949  | 8.7 |

- Brackets must be ordered separately (see below)
- **Available in color 81 - chrome finish only**
- **Weight capacity per shelf is 150 lbs., uniform load**

## basket/shelf brackets

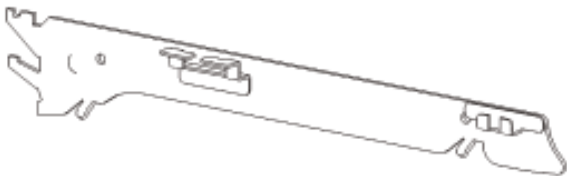

| size | part number | wt. |
|------|-------------|-----|
| 12"  | 08706-0395  | 0.7 |
| 14"  | 08706-0396  | 0.9 |
| 16"  | 08706-0397  | 1.0 |
| 18"  | 08706-0398  | 2.2 |
| 20"  | 08706-0399  | 2.6 |
| 22"  | 08706-0400  | 2.8 |
| 24"  | 08706-0401  | 3.0 |

- Painted finish, any standard color, see color chart
- Order same size as basket
- **Specify RH or LH**

# WIRE FENCING

## basket dividers

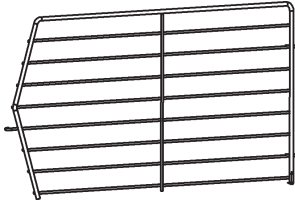

| size | part number | wt. |
|------|-------------|-----|
|------|-------------|-----|

|     |            |     |
|-----|------------|-----|
| 12" | 08303-1946 | 0.9 |
| 14" | 08303-1945 | 1.1 |
| 16" | 08303-1944 | 1.3 |

- Order same size as basket
- Available in color 81 - chrome finish only

## wire fencing

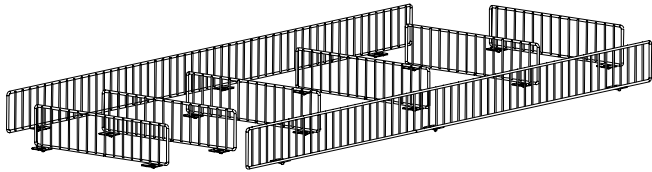

| size | part number | wt. |
|------|-------------|-----|
|------|-------------|-----|

### side to side fencing

|     |            |     |
|-----|------------|-----|
| 36" | 08303-0067 | 0.9 |
| 48" | 08303-0068 | 1.2 |

### front to back fencing

|     |            |     |
|-----|------------|-----|
| 10" | 08303-0079 | 0.3 |
| 12" | 08303-0080 | 0.4 |
| 14" | 08303-0081 | 0.4 |
| 16" | 08303-0082 | 0.5 |
| 18" | 08303-0083 | 0.5 |

- Available in color 81 - chrome finish only

# STANDARD SHELF ACCESSORIES

## bookshelf insert

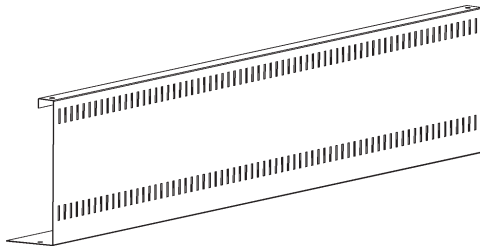

| length | part number | wt.  |
|--------|-------------|------|
| 36"    | 08445-3140  | 14.7 |
| 48"    | 08445-3141  | 19.2 |

- 7½" high back panel
- Useable space 3" less than nominal depth size
- Hooks into back row of perfs on shelf
- Order shelf separately
- See color chart for available paint colors

## steel product retainer

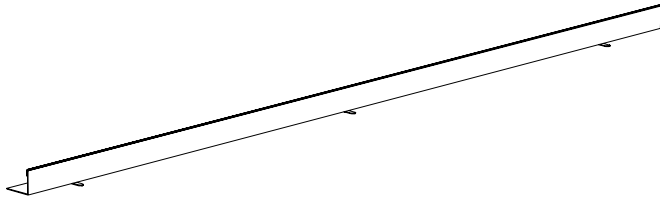

| length | part number | wt.<br>per 10 |
|--------|-------------|---------------|
| 30"    | 08402-4771  | 7.8           |
| 36"    | 08402-4772  | 8.8           |
| 48"    | 08402-4773  | 10.2          |

- 1" high steel installs in front row of perfs on shelf
- See color chart for available paint colors
- **Must be ordered in quantities of 10**

# METAL FACIA

## metal facia

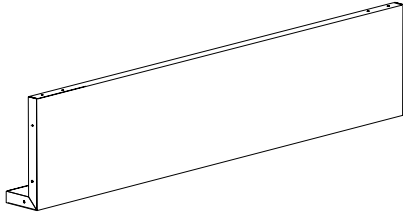

| length | part number | wt.  |
|--------|-------------|------|
| 36"    | -           | 6.7  |
| 48"    | -           | 10.0 |
| 72"    | -           | 20.0 |
| 96"    | -           | 20.0 |

- 8" high with 3" bottom flange
- Flanges at each end for connecting segments
- See color chart for available paint colors

## metal returns

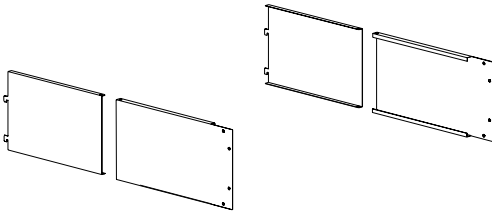

| adj. range | part number | wt.  |
|------------|-------------|------|
| 16" - 25"  | -           | 8.9  |
| 25" - 35"  | -           | 10.2 |

- Matches metal facia
- Available in two telescoping ranges: 16" to 25" & 25" to 35"
- See color chart for available paint colors

## adjustable bracket

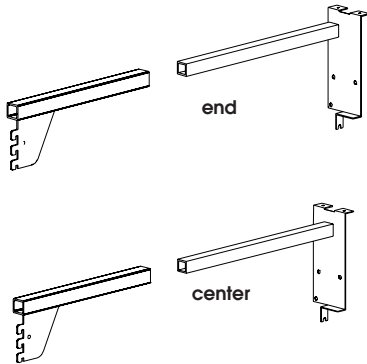

| adj. range    | part number | wt. |
|---------------|-------------|-----|
| <b>end</b>    |             |     |
| 16" to 26"    | 08706-0327  | 3.2 |
| 25" to 35"    | 08706-0329  | 3.9 |
| <b>center</b> |             |     |
| 16" to 26"    | 08706-0324  | 3.2 |
| 25" to 35"    | 08706-0333  | 3.9 |

- Used for mounting metal facia only
- Adjusts from 16" to 26" or 25" to 35" deep
- One pair end brackets required at each end of facia run, one center bracket for each joint of facia in run
- See color chart for available paint colors

## shelf mount bracket

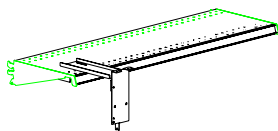

shelf not included; order separately

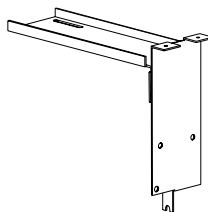

- For use with metal facia only
- One required for every upright in run

# ACCESSORIES

## wall end stabilizer

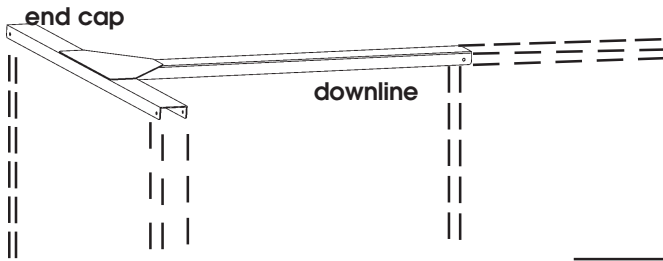

| end cap | downline | part number | wt.  |
|---------|----------|-------------|------|
| 30      | 36       | 08709-4636  | 10.9 |
| 30      | 48       | 08709-4637  | 12.4 |
| 36      | 36       | 08709-4207  | 11.7 |
| 36      | 48       | 08709-4210  | 13.1 |
| 48      | 36       | 08709-4208  | 13.1 |
| 48      | 48       | 08709-4211  | 14.7 |

- Attaches to downline and end cap to strengthen and stabilize
- See color chart for available paint colors

## flange bracket

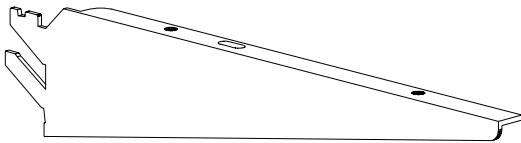

| depth | part number | wt. |
|-------|-------------|-----|
| 10    | 08401-2070  | 1.6 |
| 14    | 08401-2072  | 2.1 |
| 18    | 08401-2074  | 2.9 |
| 22    | 08401-2078  | 3.8 |

- Two-position brackets
- Specify RH or LH
- See color chart for available paint colors

## hangrod



| length | part number | wt. |
|--------|-------------|-----|
| 36"    | 08709-4097  | 5.0 |
| 48"    | 08709-4098  | 7.6 |

- Chrome rod, 1 1/4" dia.
- Requires two hangrod brackets

## hangrod brackets



| length | part number | wt. |
|--------|-------------|-----|
| 14"    | 08401-2206  | 1.4 |

- Two-position bracket: level and 15° upslant
- Adjacent brackets can be connected for continuous run
- See color chart for available paint colors